



APPROVALS



 **ENGINEERING CODE**
958BA51

 **APPROVED REFRIGERANT**
R-404A

 **POWER SUPPLY**
220-240 V 50 Hz

 **STANDARD CONDITIONS**
EN12900

 **APPLICATION**
LBP

 **COOLING CAPACITY**
211 W (LBP)

 **EFFICIENCY**
1.02 W/W (LBP)

 **MOTOR TYPE**
CSIR

 **STARTING TORQUE**
HST

DATA

General Data

Type	Hermetic reciprocating
Technology Type	On-Off
Displacement	7.37 cm ³
Compressor Cooling	Fan/NotControlled/220
Fan Air Flow	520 m ³ /h
Expansion Device	Capillary Tube or Expansion Valve
Horse Power	1/3 hp
Max Condensing Pressure Operating	24.71 bar
Max Condensing Pressure Peak	27.71 bar
Power Supply	220-240 V 50 Hz
Evaporating Temperature Range	-40 °C to -10 °C

Electrical Data

Motor type	CSIR
Starting Torque	HST
Start Winding Resistance	31.7 Ω at 25° C
Run Winding Resistance	5.18 Ω at 25° C

Mechanical Data

Maximum Recommended Refrigerant Charge	350 g
Oil Charge	350 ml
Oil Type Configuration	ESTER
Oil Type Viscosity	ISO22
Pressurization	Dry air charge
Weight	10.9 Kg
Free Internal Volume	2.1 L

Electrical Components

	Description
Start Capacitor	53-64 Uf / 330 V
Starting Device	Relay MTRP-0029*
Motor Protection	T0056/G5

External Characteristics

Base Plate	European	
Tray Holder	No	
Height	200 mm	
Connector	Internal Diameter	Shape
Suction	8.1 mm	Slanted 42°/Copper
Discharge	6.1 mm	Straight/Copper
Process	6.1 mm	Slanted 42°/Copper

PERFORMANCE

Rated Points

Condensing Temperature	Evaporating Temperature	Cooling Capacity	Power Consumption	Gas Flow Rate	Efficiency
40.00°C	-35.00°C	211 W	207 W	5.64 kg/h	1.02 W/W

Test Condition: EN12900LBP, Fan/NotControlled/220, Return Gas 20°C, Evaporation -35.00°C, Condensing 40.00°C, Ambient 35°C, Liquid 40°C, Subcooling 0K. Data are an indication of performance based simulation.

Performance Curve Data

Condensing Temperature 35°C

Evaporating Temperature °C	Cooling Capacity W	Power W	Gas Flow Rate kg/h	Efficiency W/W
-40	165	183	4.20	0.9
-35	227	208	5.79	1.09
-30	302	235	7.75	1.29
-25	392	263	10.08	1.49
-20	494	291	12.81	1.7
-15	610	318	15.93	1.92
-10	738	342	19.46	2.16

Test Condition: EN12900LBP, Fan/NotControlled/220, Return Gas 20°C, Ambient 35°C, Subcooling OK. Data are an indication of performance based simulation.

Condensing Temperature 45°C

Evaporating Temperature °C	Cooling Capacity W	Power W	Gas Flow Rate kg/h	Efficiency W/W
-35	181	212	5.26	0.85
-30	246	244	7.15	1.01
-25	322	278	9.42	1.16
-20	410	312	12.07	1.31
-15	508	346	15.12	1.47
-10	618	378	18.58	1.63

Test Condition: EN12900LBP, Fan/NotControlled/220, Return Gas 20°C, Ambient 35°C, Subcooling OK. Data are an indication of performance based simulation.

Condensing Temperature 55°C

Evaporating Temperature °C	Cooling Capacity W	Power W	Gas Flow Rate kg/h	Efficiency W/W
-30	189	251	6.44	0.75
-25	251	288	8.62	0.87
-20	323	326	11.20	0.99
-15	404	365	14.16	1.11
-10	495	403	17.53	1.23

Test Condition: EN12900LBP, Fan/NotControlled/220, Return Gas 20°C, Ambient 35°C, Subcooling OK. Data are an indication of performance based simulation.

Operating Envelope



External Dimensions



Wiring Diagram

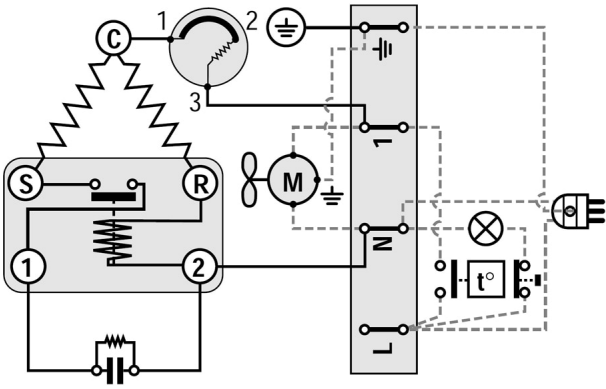

Assembly Instructions

