



APPROVALS



ENGINEERING CODE
513306236

APPROVED REFRIGERANT
R-290

POWER SUPPLY
220-240 V 50 Hz

STANDARD CONDITIONS
EN12900

APPLICATION
MBP

COOLING CAPACITY
408 W (MBP)

EFFICIENCY
2 W/W (MBP)

MOTOR TYPE
CSIR

STARTING TORQUE
HST

DATA

General Data

Type	Hermetic reciprocating
Technology Type	On-Off
Displacement	5.19 cm ³
Compressor Cooling	Fan/NotControlled/220
Expansion Device	Capillary Tube or Expansion Valve
Horse Power	1/4 hp
Power Supply	220-240 V 50 Hz
Evaporating Temperature Range	-20 °C to 10 °C

Electrical Data

Motor type	CSIR
Starting Torque	HST
Start Winding Resistance	21.3 Ω at 25° C
Run Winding Resistance	12.95 Ω at 25° C

Mechanical Data

Oil Charge	180 ml
Oil Type Configuration	ESTER
Oil Type Viscosity	ISO22
Weight	7.74 Kg

Electrical Components

	Description
Starting Device	Relay MTRP-34* QL2-3.95 ***
Motor Protection	T0250/G6
Start Capacitor	43-53 Uf/330 V

External Characteristics

Tray Holder	Yes	
Connector	Internal Diameter	Shape
Suction	6.1 mm	Slanted 42° up + 45° to Back/Copper
Discharge	4.94 mm	Slanted parallel BP+24°to Back/Copper
Process	6.1 mm	Slanted 45° up + 45° to Back/Copper

PERFORMANCE

Rated Points

Condensing Temperature	Evaporating Temperature	Cooling Capacity	Power Consumption	Gas Flow Rate	Efficiency
45.00°C	-10.00°C	408 W	204 W	5.02 kg/h	2 W/W

Test Condition: EN12900MBP, Fan/NotControlled/220, Return Gas 20°C, Evaporation -10.00°C, Condensing 45.00°C, Ambient 35°C , Liquid 45°C, Subcooling 0K. Data are an indication of performance based simulation.

Performance Curve Data

Condensing Temperature 35°C

Evaporating Temperature °C	Cooling Capacity W	Power W	Gas Flow Rate kg/h	Efficiency W/W
-20	321	164	3.55	1.95
-15	388	175	4.32	2.21
-10	466	185	5.22	2.53
-5	559	193	6.29	2.9
0	667	200	7.57	3.34
5	792	206	9.07	3.85
10	937	212	10.84	4.42

Test Condition: EN12900MBP, Fan/NotControlled/220, Return Gas 20°C, Ambient 35°C, Subcooling OK. Data are an indication of performance based simulation.

Condensing Temperature 45°C

Evaporating Temperature °C	Cooling Capacity W	Power W	Gas Flow Rate kg/h	Efficiency W/W
-20	279	176	3.40	1.58
-15	339	191	4.14	1.77
-10	408	204	5.02	2
-5	490	217	6.07	2.26
0	586	228	7.31	2.56
5	697	240	8.79	2.9
10	826	252	10.53	3.28

Test Condition: EN12900MBP, Fan/NotControlled/220, Return Gas 20°C, Ambient 35°C, Subcooling OK. Data are an indication of performance based simulation.

Condensing Temperature 55°C

Evaporating Temperature °C	Cooling Capacity W	Power W	Gas Flow Rate kg/h	Efficiency W/W
-20	238	194	3.23	1.23
-15	289	210	3.94	1.38
-10	349	225	4.79	1.55
-5	420	241	5.81	1.74
0	502	256	7.02	1.96
5	599	272	8.47	2.21
10	712	288	10.18	2.47

Test Condition: EN12900MBP, Fan/NotControlled/220, Return Gas 20°C, Ambient 35°C, Subcooling OK. Data are an indication of performance based simulation.

Operating Envelope

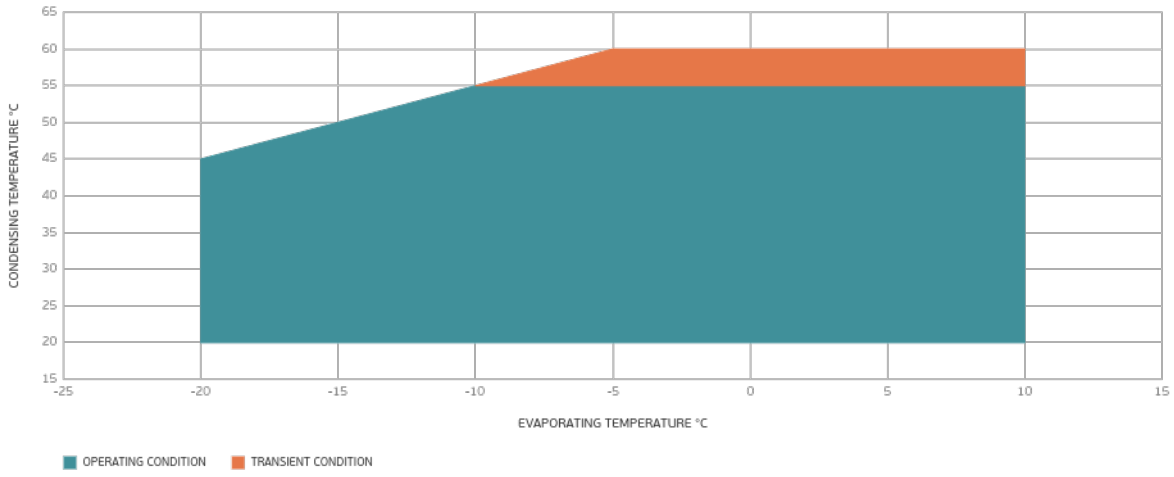

External Dimensions

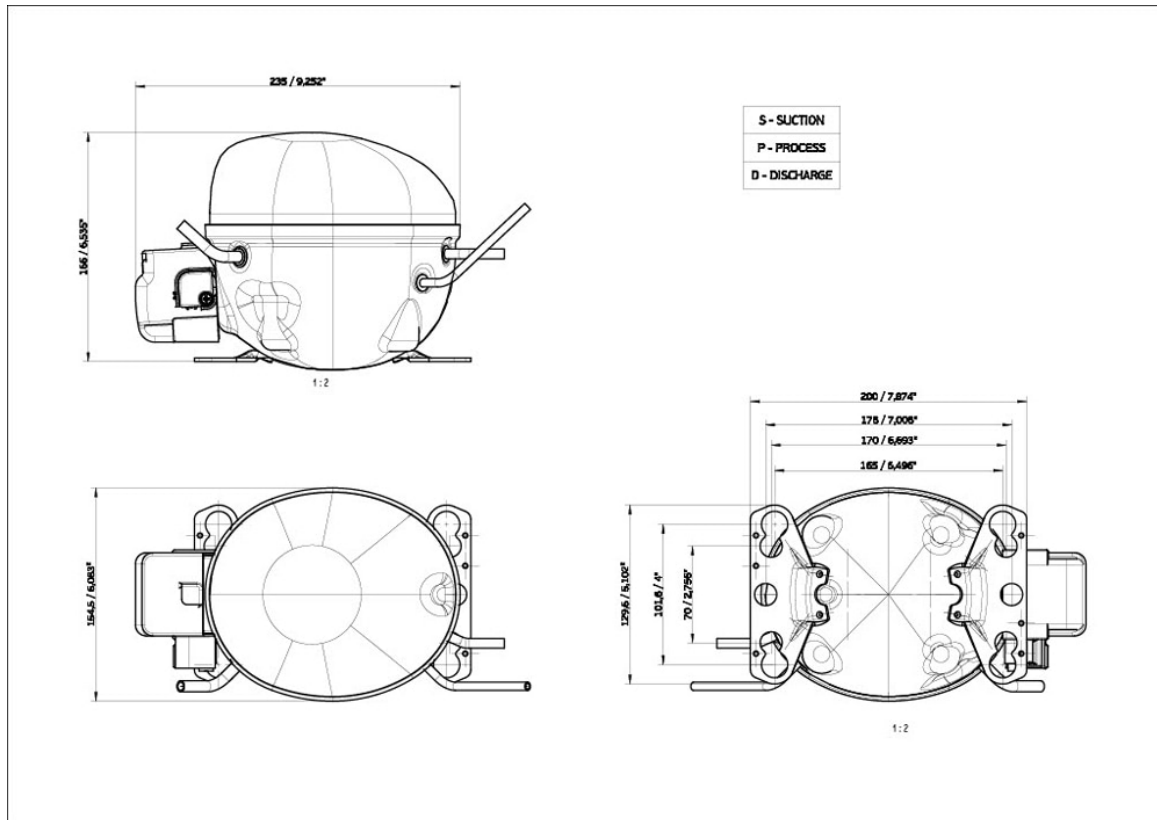

Wiring Diagram

SM28-4

